

概述

CY6N138、CY6N139 光耦合器由一个 AlGaAs LED 和一个高增益分离达林顿光电探测器组成。通过减少输入晶体管的基极-集电极电容，用于光电二极管偏置的单独连接将速度比传统的光电晶体管光耦合器提高了几个数量级。这些器件采用 8 引脚 DIP/SMD 封装，具有不同的引线形成选项。

特性

- 低电流输入: 0.5 mA
- 优越的 CTR: 2000%
- 高隔离电压: 5000Vrms
- 保证性能温度范围: 0-70°C
- 符合 RoHS

应用

- 数字逻辑地隔离
- 低电流线路接收器
- 电话响铃检测器
- 微处理器总线隔离
- CMOS-LSTTL-TTL 输出接口

电路结构和封装

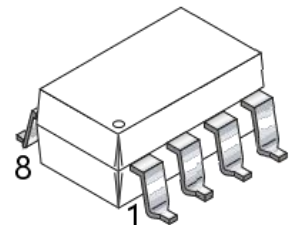
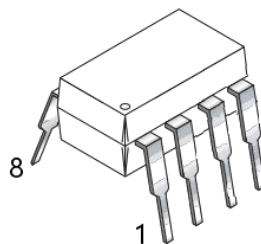
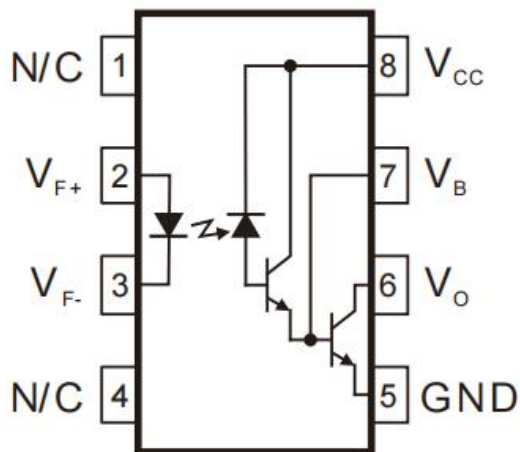

极限参数 (T_A = 70°C 除非特别说明)

符号	参数	数值	单位	
T _{STG}	储存温度	-55~+125	°C	
T _{OPR}	工作温度	-40~+85	°C	
T _J	结温	-40~+125	°C	
T _{SOL}	焊线温度 (仅适用于回流焊)	260 (10 s)	°C	
发射				
I _{F(AVG)}	DC 平均输入电流	20	mA	
I _{F(PK)}	峰值输入电流 (50% 占空比, 1 ms 脉宽)	40	mA	
I _{F(TRANS)}	峰值瞬态输入电流 (≤1μs 脉宽, 300 pps)	1	A	
V _R	反向输入电压	5.0	V	
P _D	输入功耗	35	mW	
接收				
I _{O(AVG)}	平均输出电流	60	mA	
V _{EBR}	发射极-基极 反向电压	0.5	V	
V _{CC}	电源电压	CY6N138	-0.5 to 7.0	V
		CY6N139	-0.5 to 18	
V _O	输出电压	CY6N138	-0.5 to 7.0	V
		CY6N139	-0.5 to 18	
P _O	输出功率	100	mW	

光电参数 (T_a=0 to 70°C 除非特别说明)

参数	符号	条件	最小值	典型	最大值	单位
发射						
正向电压	V _F	I _F = 1.6mA, T _A = 25°C		1.30	1.70	V
		I _F = 1.6mA			1.75	
反向击穿电压	B _{VR}	I _R = 10μA	5.0			V
二极管温度系数	ΔV _F /ΔT _A	I _F = 1.6mA		-1.94		mV/°C
接收						
高电平输出电流	CY6N138	I _F = 0mA, V _O =V _{CC} =7V, T _A =25°C			250	uA
	CY6N139		I _F = 0mA, V _O =V _{CC} =18V, T _A =25°C		100	
低电平电源电流	I _{CCL}	I _F = 1.6mA, V _O =Open V _{CC} =18V, T _A =25°C		0.4	1.5	mA
高电平电源电流	I _{CCH}	I _F = 0mA, V _O =Open V _{CC} =18V, T _A =25°C			10	uA

参数	符号	条件	最小值	典型	最大值	单位	
耦合							
电流传输比	CY6N138	CTR	$I_F = 1.6\text{mA}, V_O = 0.4\text{V}$ $V_{CC} = 4.5\text{V}$	300	1600	%	
	CY6N139	CTR	$I_F = 1.6\text{mA}, V_O = 0.4\text{V}$ $V_{CC} = 4.5\text{V}$	500	1600		
			$I_F = 0.5\text{mA}, V_O = 0.4\text{V}$ $V_{CC} = 4.5\text{V}$	400	2000		
低电平输出电压	CY6N138	V_{OL}	$I_F = 1.6\text{mA}, I_O = 4.8\text{mA}$ $V_{CC} = 4.5\text{V}$		0.1	0.4	V
	CY6N139	V_{OL}	$I_F = 0.5\text{mA}, I_O = 2.0\text{mA}$ $V_{CC} = 4.5\text{V}$		0.1	0.4	
			$I_F = 1.6\text{mA}, I_O = 8.0\text{mA}$ $V_{CC} = 4.5\text{V}$		0.1	0.4	
			$I_F = 5\text{mA}, I_O = 15\text{mA}$ $V_{CC} = 4.5\text{V}$		0.1	0.4	
			$I_F = 12\text{mA}, I_O = 24\text{mA}$ $V_{CC} = 4.5\text{V}$		0.2	0.4	

开关特性 ($T_A = 0$ to 70°C 除非特别说明)

交流特性	符号	条件	最小值	典型值	最大值	单位	
输出高电平延迟时间	CY6N138	T_{PLH}	$T_A = 25^\circ\text{C}, R_L = 2.2\text{K}\Omega, I_F = 1.6\text{mA}$		11	35	μs
			$R_L = 2.2\text{K}\Omega, I_F = 1.6\text{mA}$			50	
	CY6N139	T_{PLH}	$T_A = 25^\circ\text{C}, R_L = 270\Omega, I_F = 12\text{mA}$		2.1	7	
			$R_L = 270\Omega, I_F = 12\text{mA}$			10	
			$T_A = 25^\circ\text{C}, R_L = 4.7\text{K}\Omega, I_F = 0.5\text{mA}$		22	60	
$R_L = 4.7\text{K}\Omega, I_F = 0.5\text{mA}$			90				
输出低电平延迟时间	CY6N138	T_{PHL}	$T_A = 25^\circ\text{C}, R_L = 2.2\text{K}\Omega, I_F = 1.6\text{mA}$		1.4	10	μs
			$R_L = 2.2\text{K}\Omega, I_F = 1.6\text{mA}$			15	
	CY6N139	T_{PHL}	$T_A = 25^\circ\text{C}, R_L = 270\Omega, I_F = 12\text{mA}$		0.2	1	
			$R_L = 270\Omega, I_F = 12\text{mA}$			2	
			$T_A = 25^\circ\text{C}, R_L = 4.7\text{K}\Omega, I_F = 0.5\text{mA}$		5	25	
$R_L = 4.7\text{K}\Omega, I_F = 0.5\text{mA}$			30				
高电平共模抑制比	$ CM_H $	$T_A = 25^\circ\text{C}, V_{CM} = 10\text{V}_{P-P}$ $I_F = 0\text{mA}, R_L = 2.2\text{K}\Omega$	1000			$\text{V}/\mu\text{s}$	
低电平共模抑制比	$ CM_L $	$T_A = 25^\circ\text{C}, V_{CM} = 10\text{V}_{P-P}$ $I_F = 1.6\text{mA}, R_L = 2.2\text{K}\Omega$	1000			$\text{V}/\mu\text{s}$	

隔离特性 ($T_A = 0\text{C to } 70\text{C}$ 除非特别说明.)

参数	符号	条件	最小值	典型值	最大值	单位
隔离电压	V_{ISO}	$RH < 50\%$, $f = 50\text{Hz}$, $I_{I-O} \leq 10\mu\text{A}$, $t = 1 \text{ min.}$	5000			V_{RMS}
隔离电阻(输入-输出)	R_{I-O}	$V_{I-O} = 500V_{DC}$		10^{12}		Ω
隔离电容(输入-输出)	C_{I-O}	$f = 1\text{MHz}$, $V_{I-O} = 0V_{DC}$		0.6		pF
隔离漏电流(输入-输出)	I_{I-O}	$RH=45\%$, $T_A=25\text{C}$, $t=5\text{s}$, $V_{I-O}=3000V_{DC}$			1.0	μA

备注:

1. 电流传输比定义为输出集电极电流 I_O 与 LED 正向输入电流 I_F 之比乘以 100%。
2. 设备被认为是一个双终端设备: 引脚 1、2、3 和 4 短接在一起, 引脚 5、6、7 和 8 短接在一起。

测试电路

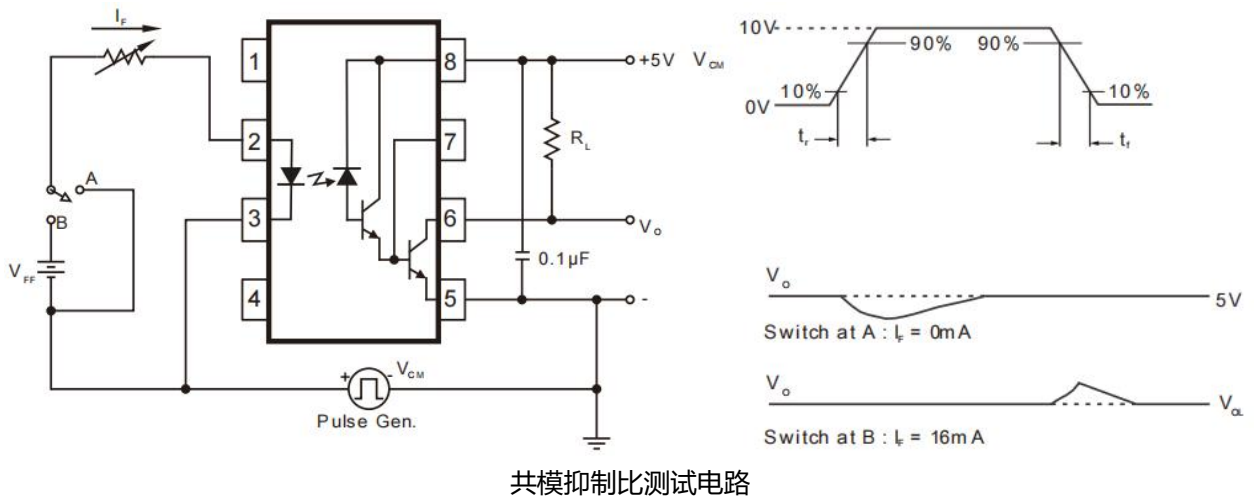
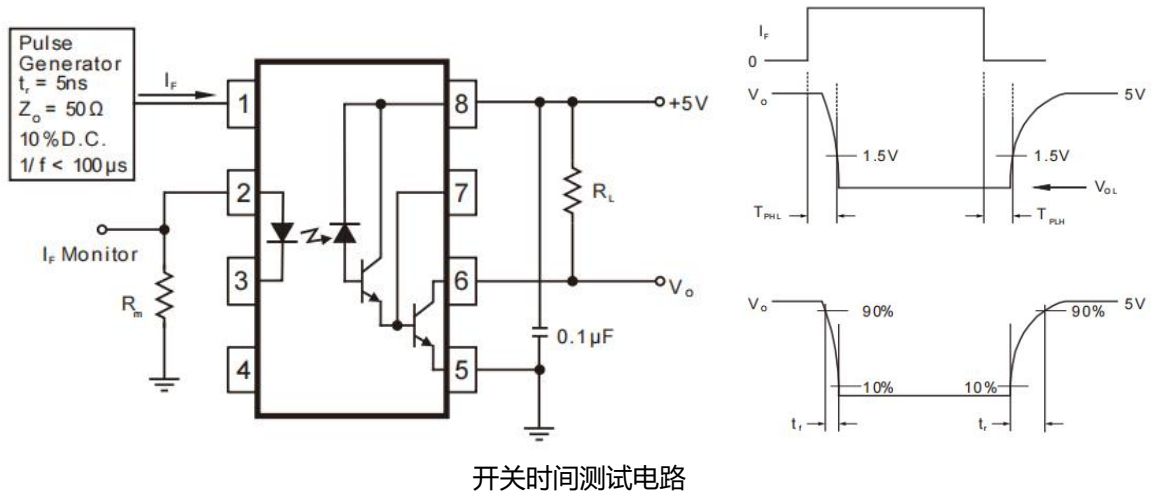

特性曲线

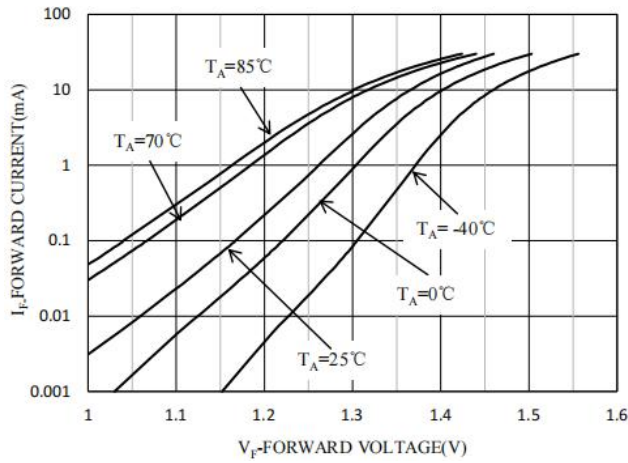

Fig.1 Forward Current vs. Forward Voltage

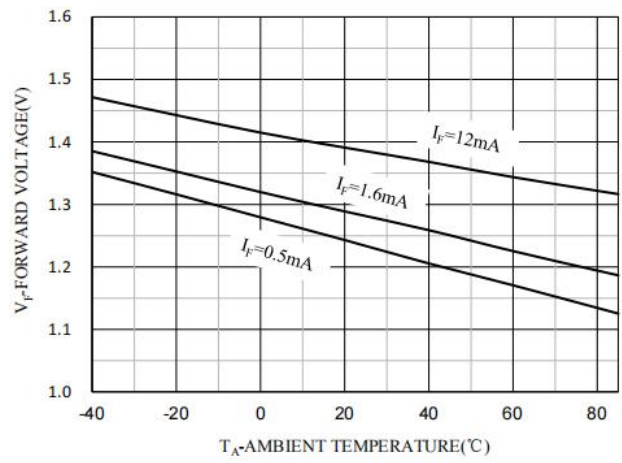

Fig.2 Forward Voltage vs. Ambient Temperature

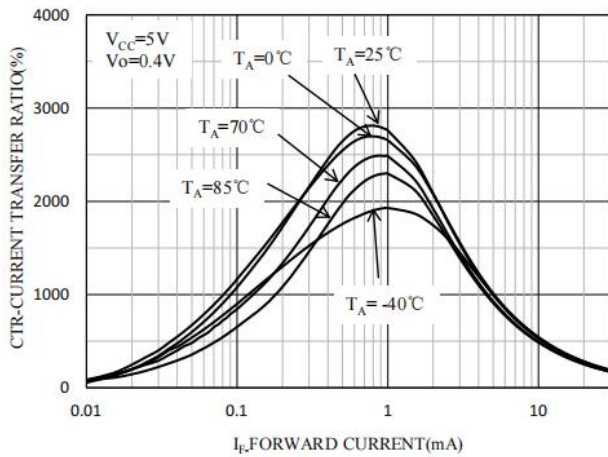

Fig.3 Current Transfer Ratio vs. Forward Current

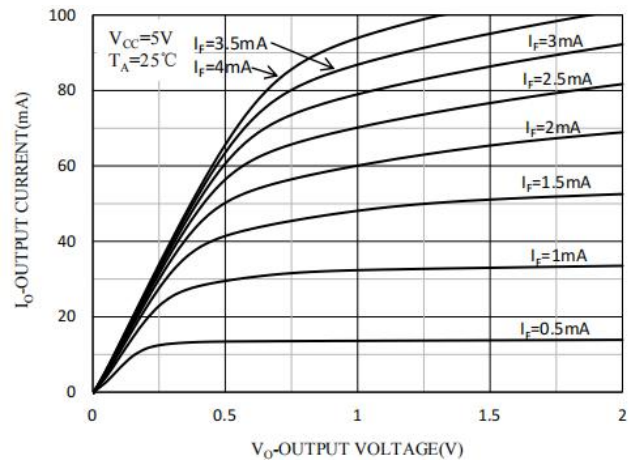

Fig.4 Output Current vs. Output Voltage

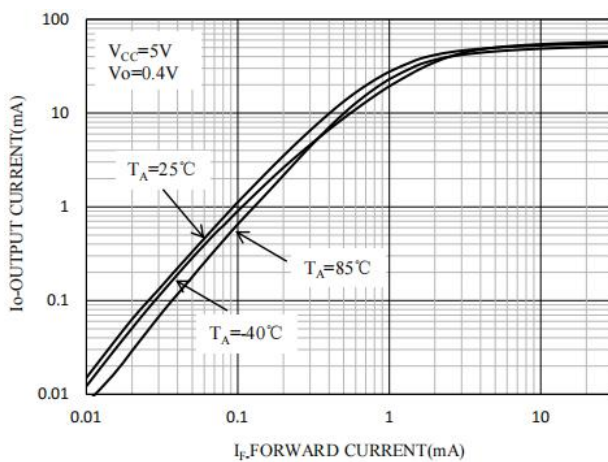

Fig.5 Output Current vs. Forward Current

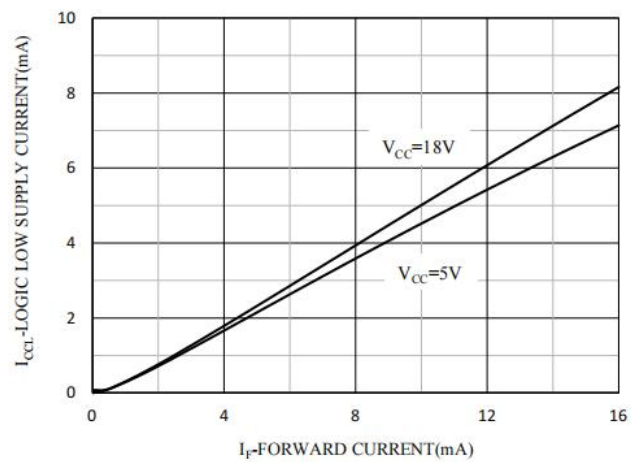

Fig.6 Logic Low Supply Current vs. Forward Current

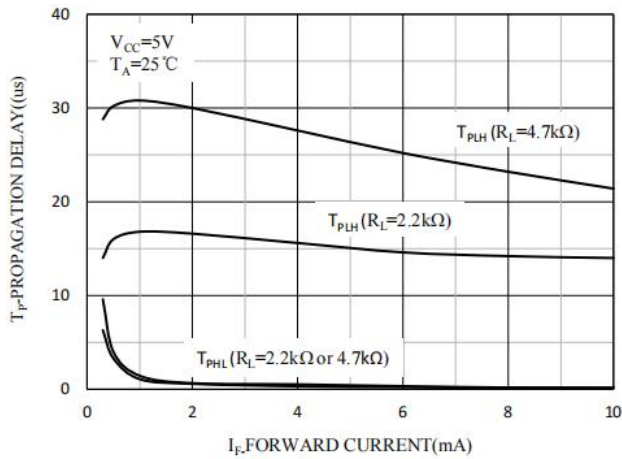

Fig.7 Propagation Delay vs. Forward Current

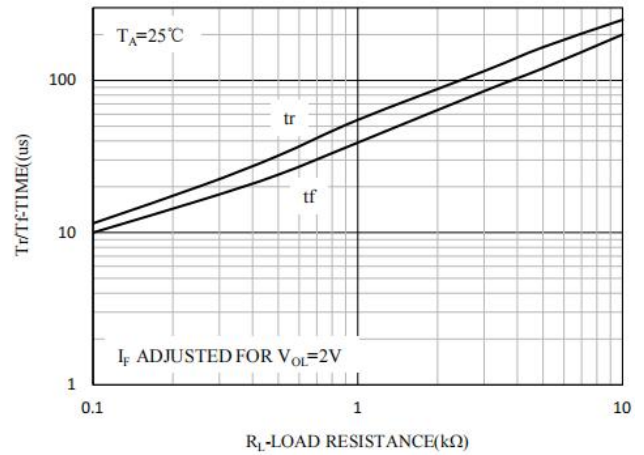

Fig.8 Non-saturated Rise and Fall Time vs. Load Resistance

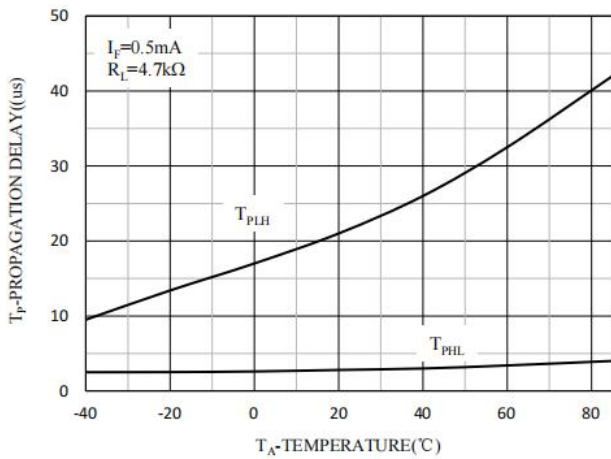

Fig.9 Propagation Delay vs. Temperature

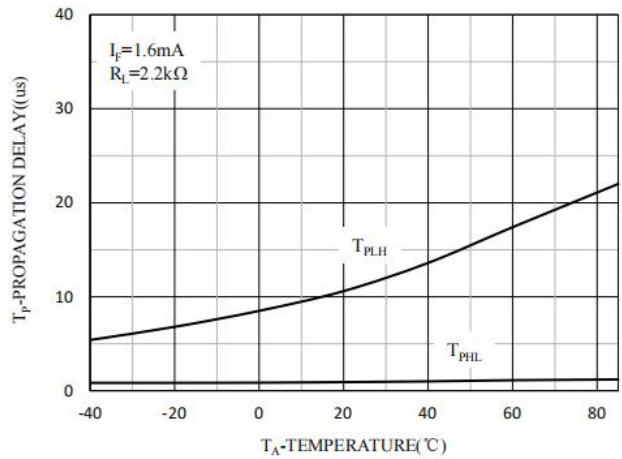

Fig.10 Propagation Delay vs. Temperature

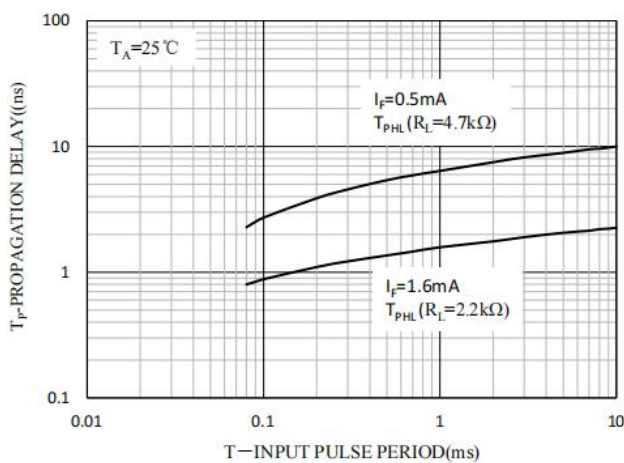

Fig.11 Propagation Delay vs. Input Pulse Period

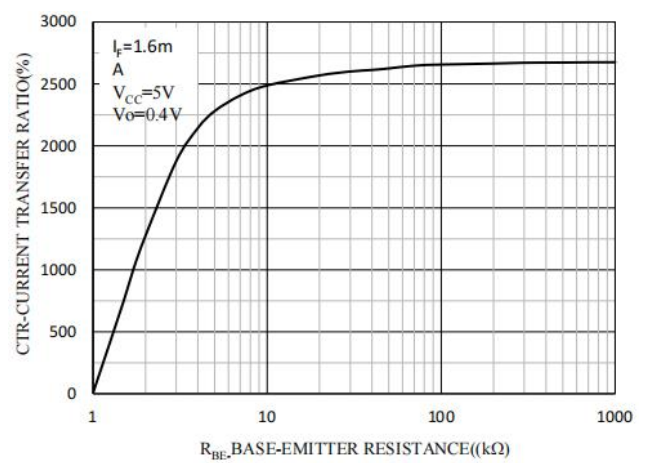
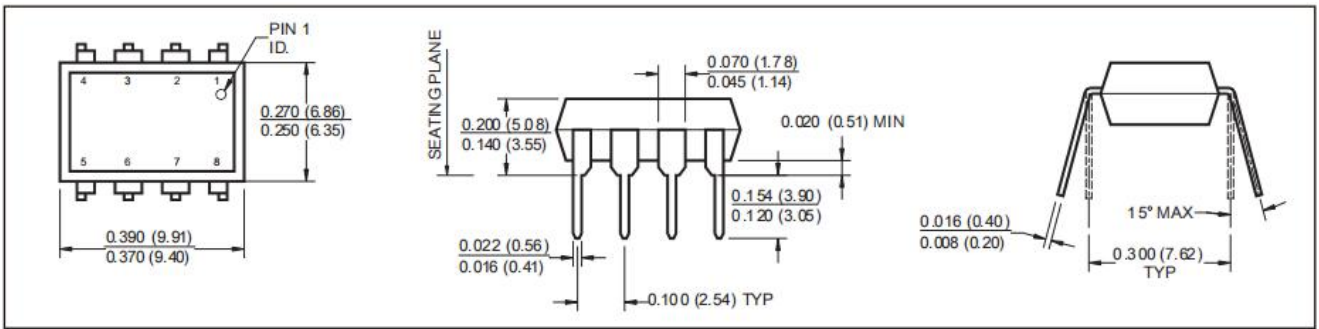
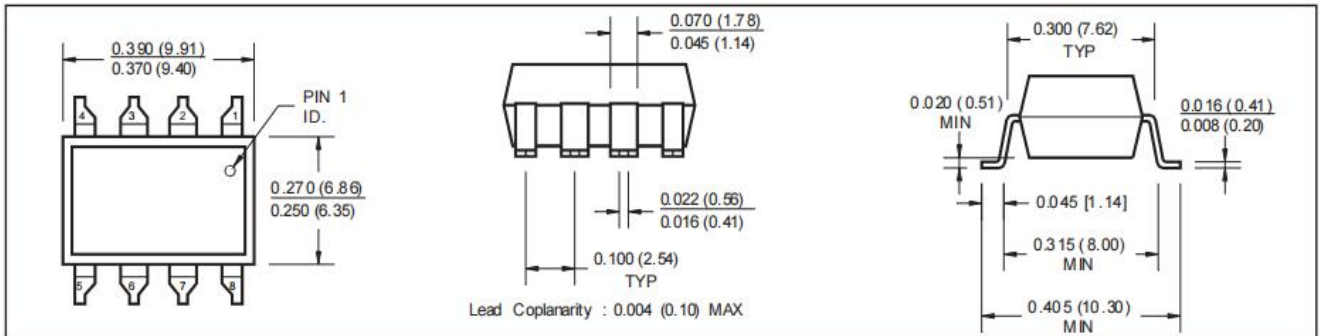

Fig.12 Current Transfer Ratio vs. Base-Emitter Resistance

封装尺寸



DIP-8

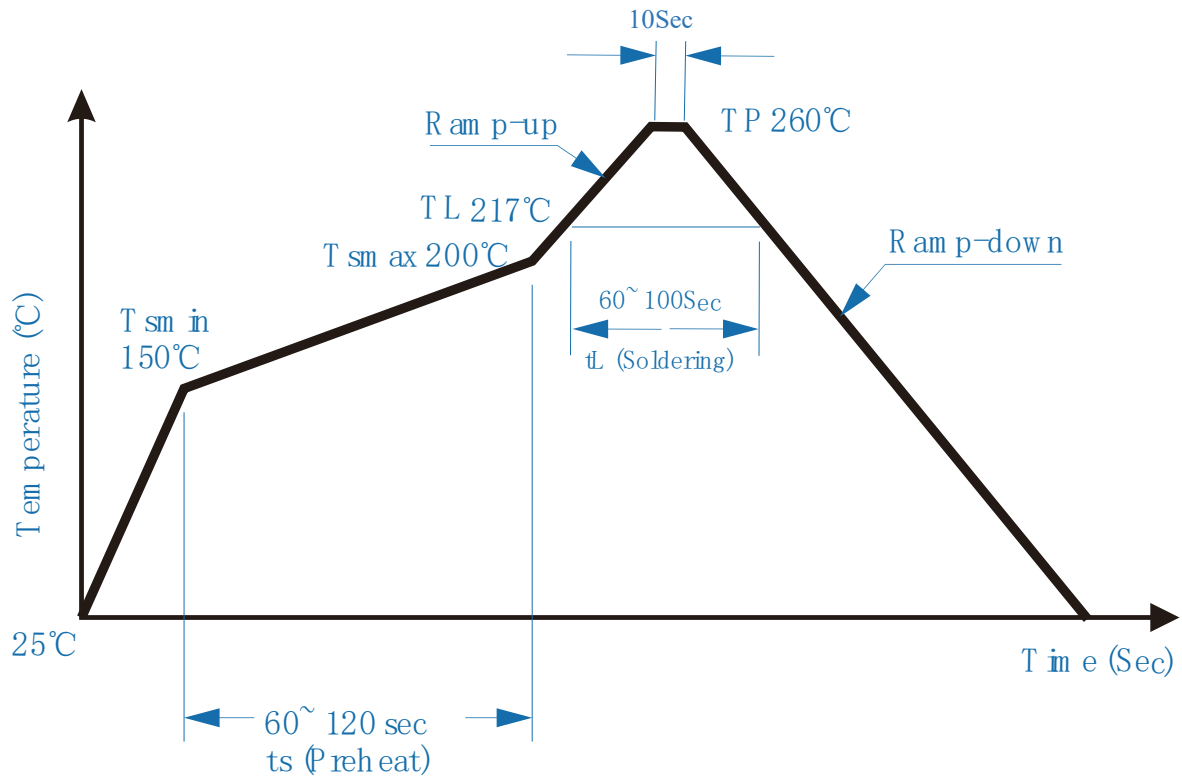

SMD-8

回流焊曲线

注意:

- 卓睿研发会持续不断改善质量、可靠性、功能或设计和提供更好的产品，保留在任何时候修改此规格的权利，恕不另行通知。
- 客户下单之前请确认手头的资料是最新版本，客户需确认此芯片确实符合自己的需要且能满足自己的要求。
- 请遵守产品规格书使用，卓睿研发不对使用时不符合产品规格书条件而导致的质量问题负责。
- 如需要高可靠性且用于以上特定设备或装置的产品，如军事、核电控制、医疗、生命维持或救生等可能导致人身伤害或死亡的设备或装置，请联系我们销售代表以获取建议。
- 使用此产品时请采取措施防止静电损坏。
- 如对文件中表述的内容有疑问，欢迎联系我们。